



Pallet Trucks

T16 L

Capacity 1.6 t | Series 1155

PB ION

Ergonomic all-rounder

- Ideal for transport, loading and unloading, and order picking
- High operating speeds, even when fully loaded
- Lifting function (L) reduces strain on operator's back when order picking
- Ergonomic tiller head enables intuitive operation
- Low skirt and long tiller for optimum protection of operator



STANDARD AND OPTIONAL EQUIPMENT

Manufacturer's type designation/equipment		T16 L
Safety	Active foot bumper – assistant system for foot protection	<input type="radio"/>
	Long tiller and low chassis skirt	<input checked="" type="radio"/>
	Automatic speed reduction when cornering	<input checked="" type="radio"/>
	Easily accessible emergency stop button	<input checked="" type="radio"/>
	Warning buzzer (in place of horn) – preferable where low noise emission required	<input checked="" type="radio"/>
	Horn – preferable for noisy environment	<input type="radio"/>
	Key switch	<input checked="" type="radio"/>
	Log in PIN code	<input type="radio"/>
Service	CAN bus technology	<input checked="" type="radio"/>
Digital-isation	Data transmission online	<input type="radio"/>
	Data transmission Wifi	<input type="radio"/>
	Linde connect:ac pre-shift check – app for operator to report truck condition before use	<input type="radio"/>
	Linde connect:dt crash detection – allows electronic impact damage monitoring	<input type="radio"/>
Operation/load handling	Ergonomic lift h = 675 mm	<input checked="" type="radio"/>
	Automatic lifting – up and down	<input type="radio"/>
	Extra side buttons – up and down	<input type="radio"/>
	Lift end stop sensor	<input checked="" type="radio"/>
	Proportional speed control – speed dependent on tiller angle	<input checked="" type="radio"/>
	Creep speed – for operation with tiller in vertical position	<input type="radio"/>
	Multifunction display – hour meter, maintenance indication, battery discharge indicator and internal fault code indication	<input checked="" type="radio"/>
	Ergonomic tiller head with easy access to all controls	<input checked="" type="radio"/>
	Load backrest h = 900 mm or 1290 mm – height from top of forks	<input type="radio"/>
	Accessory support	<input type="radio"/>
	Support for clipboard and scanner	<input type="radio"/>
Environment	Metal battery cover	<input type="radio"/>
Attachment/forks	Coldstore protection -35°C (in/out)	<input type="radio"/>
	Fork widths: 520 mm, 535 mm, 560 mm	<input type="radio"/>
	Fork length: 1150 mm with overhang 205 mm	<input type="radio"/>
Axles and tyres	Fork length: 1190 mm with overhang 245 mm	<input type="radio"/>
	Drive wheel, standard duty	<input checked="" type="radio"/>
	Drive wheel heavy duty, high grip	<input type="radio"/>
	Single load wheel, polyurethane	<input checked="" type="radio"/>
	Tandem load wheels, polyurethane	<input type="radio"/>
	Tandem load wheels, polyurethane greasable	<input type="radio"/>
	Castor wheels	<input checked="" type="radio"/>
Auto-adjustable castor wheels	<input type="radio"/>	
Drive and brake system	Maintenance-free AC motor	<input checked="" type="radio"/>
	Electromagnetic braking system	<input checked="" type="radio"/>
	Battery compartment, vertical change compact	<input type="radio"/>
	Battery compartment, 2 PzS-B, vertical change	<input checked="" type="radio"/>
Energy	Battery compartment, 2 PzS, lateral or vertical change	<input type="radio"/>
	Li-ION technology available – different battery capacities with front, lateral or vertical mounted opportunity charging plug	<input type="radio"/>
	Lead-acid battery technology	<input type="radio"/>
	On-board charger 35 A or 70 A for lead-acid and Li-ION batteries	<input type="radio"/>
External chargers available	<input type="radio"/>	

Standard equipment

Optional equipment

TECHNICAL DATA (according to VDI 2198)

Characteristics	1.1	Manufacturer (abbreviation)		Linde MH
	1.2	Manufacturer's type designation		T16 L
	1.2a	Series		1155
	1.3	Drive		Battery
	1.4	Operator type		Pedestrian
	1.5	Rated capacity/rated load	Q (t)	1.6 ¹⁾
	1.6	Load centre distance	c (mm)	600
	1.8	Load distance, centre of drive axle to fork	x (mm)	873/936 ²⁾³⁾
	1.9	Wheelbase	y (mm)	1306/1369 ²⁾³⁾⁴⁾
Weight	2.1	Service weight	kg	527 ⁵⁾
	2.2	Axle loading, laden front/rear	kg	711/1416 ⁵⁾⁶⁾
	2.3	Axle loading, unladen front/rear	kg	377/150 ⁵⁾⁶⁾
Tyres/chassis	3.1	Tyres		Polyurethane
	3.2	Tyre size, front		Ø 230 × 75
	3.3	Tyre size, rear		Ø 85 × 80 (Ø 85 × 60) ⁷⁾
	3.4	Auxiliary wheels (dimensions)		Ø 125 × 40
	3.5	Wheels, number front/rear (x = driven wheels)		1x + 2/2 (1x + 2/4) ⁷⁾
	3.6	Tread, front	b10 (mm)	482 ³⁾
	3.7	Tread, rear	b11 (mm)	340/353/378 ³⁾⁸⁾
Dimensions	4.2	Height of mast, lowered	h1 (mm)	891
	4.3	Free lift	h2 (mm)	550
	4.4	Lift	h3 (mm)	550 ³⁾
	4.5	Height, mast extended	h4 (mm)	1016
	4.6	Initial lift	h5 (mm)	125
	4.9	Height drawbar in operating position min./max.	h14 (mm)	720/1240 ³⁾
	4.10	Height of wheel arms	h8 (mm)	60
	4.15	Height, lowered	h13 (mm)	86 ⁹⁾
	4.19	Overall length	l1 (mm)	1742 ³⁾⁴⁾
	4.20	Length to face of forks	l2 (mm)	592 ³⁾⁴⁾
	4.21	Overall width	b1/b2 (mm)	720 ³⁾
	4.22	Fork dimensions DIN ISO 2331	s/e/l (mm)	60/182/1150
	4.24	Fork carriage width	b3 (mm)	514/529/554
	4.25	Fork spread	b5 (mm)	520/535/560 ³⁾
	4.31	Ground clearance, laden, below mast	m1 (mm)	20/145 ¹⁰⁾¹¹⁾
	4.32	Ground clearance, centre of wheelbase	m2 (mm)	20/145 ¹⁰⁾¹¹⁾
	4.33	Load dimension b12 × l6	b12 × l6 (mm)	1200 × 800
	4.34	Aisle width predetermined load dimensions	Ast (mm)	2316 ⁴⁾¹²⁾¹³⁾
	4.34.1	Aisle width for pallets 1000 × 1200 crossways	Ast (mm)	2325 ⁴⁾¹²⁾¹³⁾
	4.34.2	Aisle width for pallets 800 × 1200 lengthways	Ast (mm)	2229 ⁴⁾¹²⁾¹³⁾
4.35	Turning radius	Wa (mm)	1512/1575 ⁷⁾⁴⁾	
Performance	5.1	Travel speed, laden/unladen	km/h	6/6 ⁴⁾
	5.1.1	Travel speed, laden/unladen, backwards	km/h	6/6 ⁴⁾
	5.2	Lifting speed, laden/unladen	m/s	0.094/0.152 ⁵⁾
	5.3	Lowering speed, laden/unladen	m/s	0.352/0.133 ⁵⁾
	5.8	Maximum climbing ability, laden/unladen	%	10.0/20.0
	5.9	Acceleration time, laden/unladen	s	7.0/6.6
	5.10	Service brake		Electromagnetic
Electric-engine	6.1	Drive motor rating S2 60 min	kW	1.3
	6.2	Lift motor rating at S3 15%	kW	1.2
	6.3	Battery according to DIN 43531/35/36 A, B, C, no		Li-ION compact
	6.4	Battery voltage/nominal capacity K5	(V)/(Ah) o. kWh	24/62 (125) ¹⁵⁾
	6.5	Battery weight (±5%)	kg	14/23 ¹⁰⁾
	6.6	Energy consumption according to DIN EN 16796	kWh/h	0.19
	6.6.1	CO ₂ equivalent according to DIN EN 16796	kg/h	0.11
	6.7	Turnover output according to VDI 2198	t/h	96.0
6.8	Turnover efficiency according to VDI 2198	t/kWh	167	
Drive	8.1	Type of drive unit		AC control
Additional data	10.7	Sound pressure level LpAZ (at the operator's seat)	dB(A)	61 ¹⁶⁾

- 1) 1600 kg on the load arms (initial lift) – reduced to 800 kg on the lifted forks (auxiliary lift)
- 2) Forks upraised/lowered
- 3) (±5 mm)
- 4) +50 mm = BS battery (2PzS-B); +105 mm = 2 PzS battery
- 5) (±10%)
- 6) Figures with battery, see line 6.4/6.5

- 7) Figures in parenthesis with tandem load wheels
- 8) Depending on the forks spread; see 4.25
- 9) (-0/+5 mm)
- 10) Min./max.
- 11) (±2 mm)
- 12) Including a 200 mm (min.) operating aisle clearance

- 13) With creep speed = tiller in vertical position
- 14) (±5%)
- 15) (Option)
- 16) (±2.5)

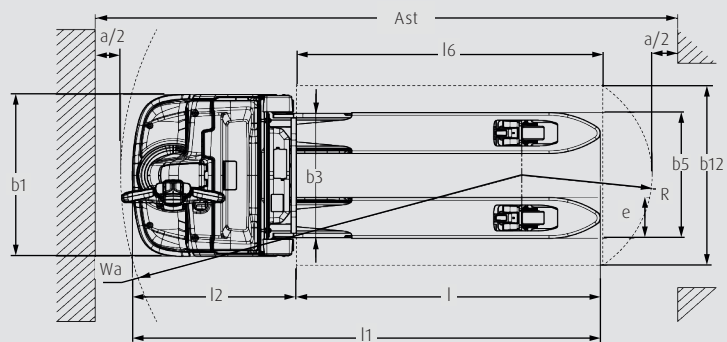
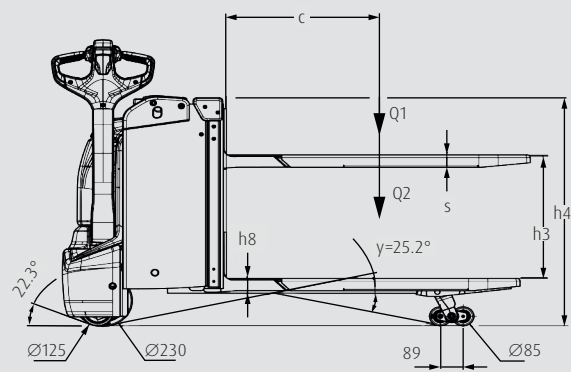
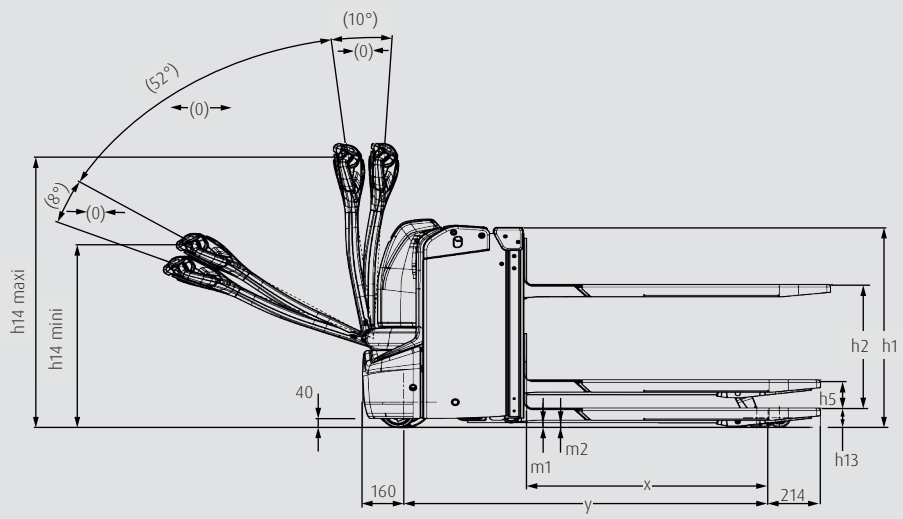

CHARACTERISTICS



Long tiller and low rounded chassis

Safety

- Long, low-mounted tiller creates large safety distance
- Automatic speed adjustment when cornering
- Deep rear skirt covers wheels and protects operator's feet
- Easy-to-reach emergency stop button ensures safety in case of emergency
- Tiller head encloses hands and protects against injury
- Low chassis skirt and active foot bumper (option) protect the operator

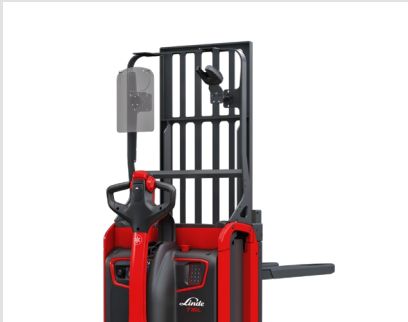

Ergonomic lift for effortless operation

Ergonomics

- Comfortable working height protects operator's back and knees
- Speed and steering resistance adapt to the steering angle
- Tiller head can also be operated with one hand and when wearing gloves
- Optional autolift automatically adjusts lift height to load
- Optional switch, on right side, for easy control of the lift height



Castor wheels for high operating stability

Handling

- Transport load capacity up to 1600 kg (on initial lift)
- Load capacity up to 800 kg on the ergonomic lift
- Speeds up to 6 km/h laden and unladen
- Maximum performance on inclines, even when fully loaded
- Optional castor wheels automatically adjust to load and operating situation
- Creep speed function (optional) and proportional speed control



Easy access to all relevant components

Service

- Robust design for low maintenance costs and long service life
- CAN bus structure allows quick truck diagnosis and service
- Easy access to major components for fast maintenance
- Covers are protected from damage by the contours of the chassis
- Steel-reinforced tiller arm ensures additional robustness

Subject to modification in the interest of progress. Illustrations and technical specifications could include options and are not binding for actual constructions. All dimensions subject to usual tolerances.

Linde Material Handling

Linde

ncnielsen

Nørregade 66, DK-7860 Balling | Tlf.: +45 99 83 83 83
nc-nielsen.dk | info@nc-nielsen.dk